

# SP25A1/SP25V1

## THE PUP

1/4 HP Residential  
Sump Pump



### ADVANTAGES BY DESIGN

**DURABLE CONSTRUCTION TO DELIVER MANY YEARS OF RELIABLE SERVICE.**

- Wide angle or vertical switch.
- Dual ball bearing.
- Powerful capacitor run motor.
- Built-in overload protection.
- Cast iron housing for superior heat dissipation.
- Non-clogging recessed impeller.
- Long life carbon/ceramic seal.
- Positive sealing, quick-disconnect power and switch cords make replacement simple.
- 10' power cord.
- Energy saving, low amp motor.

### PRODUCT CAPABILITIES

Capacities To	32 gpm	121 lpm
Lifts To	22 ft.	6.7 m
Pump Down Range (float)	7 in.	178 mm
(vertical)	4 1/8 in.	107 mm
Solids Handling Capacity	1/4 in.	6.4 mm
Liquids Handling	drain water	
Intermittent Liquid Temp.	140°F	60°C
Motor Electrical Data	6.5 amp, 115V 1Ø, 60 Hz	
Third Party Approvals	UL, CSA	
Float Switches	mercury-free	
Mechanical Seal	carbon/ceramic	
Power Cord, 10' long	SJTW, SJTW-A	
Discharge, NPT	1.5" in.	38.4 mm
Min. Sump Dia. (float)	18 in.	457 mm
(vertical)	10' in.	267 mm

### PERFORMANCE

Head	GPM
5'	27
10'	21
15'	15
20'	6

WHERE INNOVATION MEETS TRADITION

**T**HE SP25A1 AND SP25V1 ARE THE PLUMBER'S BEST FRIENDS. THESE ECONOMICAL 1/4 HP SUBMERSIBLE SUMP PUMPS ARE EXCELLENT ALTERNATIVES TO LARGER, MORE EXPENSIVE PUMPS. The SP25A1/SP25V1 are the ideal compact sump pumps for residential sump drainage, depending on which type of float you prefer. Contact your Myers distributor, or the Myers Ohio sales office at 419-289-1144 for more details.

# SP25A1/SP25V1

**THE PUP**  
1/4 HP Residential  
Sump Pump

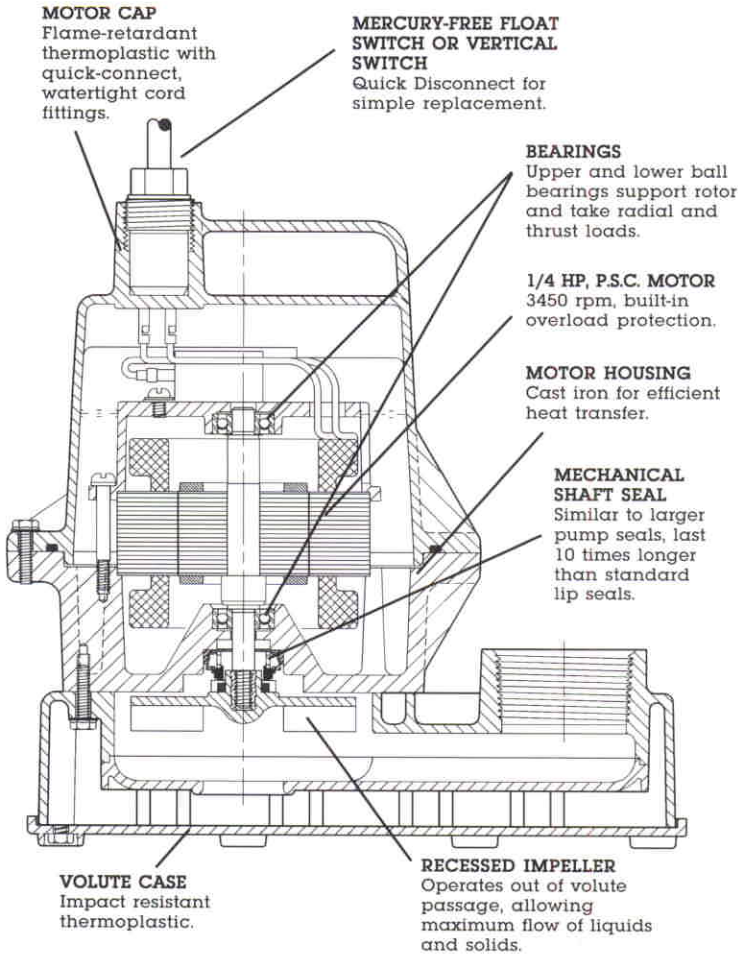

## PERFORMANCE CURVE

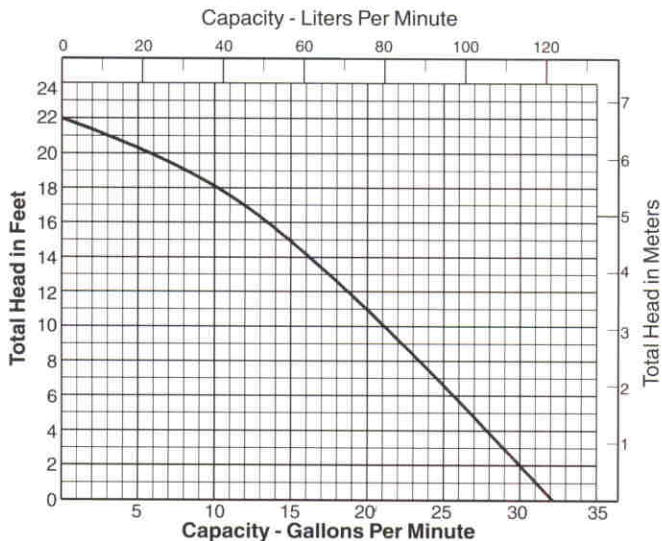

## DIMENSIONS

[ ] dimensions in mm

### SP25A1

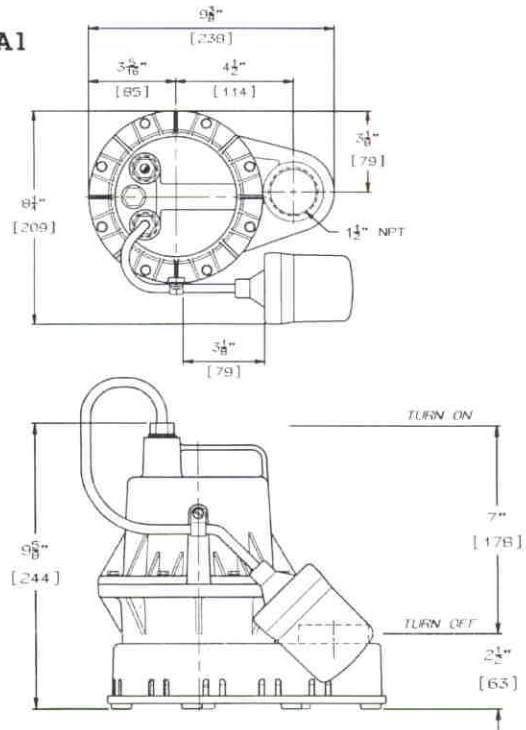

### SP25V1

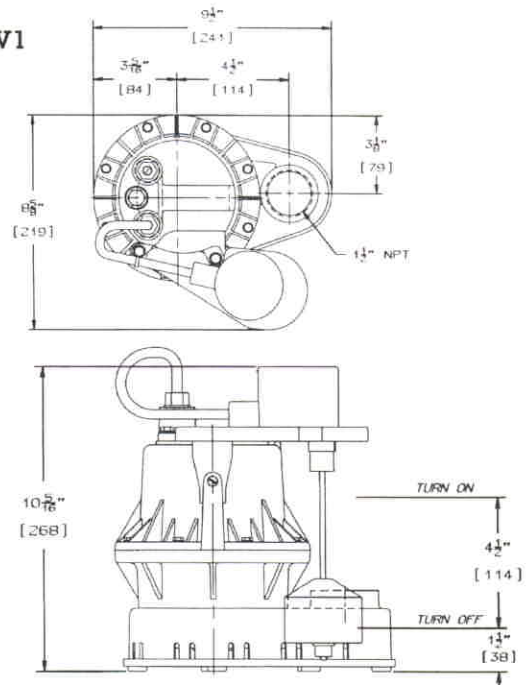

K3196 3/01  
Printed in U.S.A.



**Myers**<sup>®</sup>  
Pentair Pump Group

F. E. Myers, 1101 Myers Parkway, Ashland, Ohio 44805-1969  
419/289-1144, FAX: 419/289-6658, www.femyers.com

Myers (Canada), 269 Trillium Drive, Kitchener, Ontario N2G 4W5  
519/748-5470, FAX: 519/748-2553