

P50 and P100 SERIES

1/2 and 1 HP
Effluent S.T.E.P. Pumps



THE MYERS P SERIES EFFLUENT PUMPS ARE DESIGNED SPECIFICALLY FOR TODAY'S MULTI-PUMP PRESSURE COLLECTION AND SEPTIC TANK EFFLUENT PUMPING (S.T.E.P.) SYSTEMS AND HIGH HEAD DRAINAGE APPLICATIONS. The P Series effluent pumps with their high efficiency, single vane, enclosed impellers provide the steep non-overloading performance curves ideal for pressure collection and S.T.E.P. systems. Myers 1/2 and 1 horsepower P Series pumps deliver more capacity at higher heads than most 1, 1 1/2 and 2 horsepower pumps in their class. Myers P Series pumps are constructed of only the highest quality corrosion resistant materials like cast iron, stainless steel and thermoplastics to assure that they will perform for years to come in the harsh effluent environment and drainage applications. For more information, call your Myers distributor today or the Myers, Ohio sales office at 419-289-6898.

ADVANTAGES BY DESIGN

OPTIMUM PERFORMANCE FOR USE IN MULTI-PUMP PRESSURE COLLECTION AND S.T.E.P. SYSTEMS

- High efficiency, single vane, enclosed impeller provides non-overloading performance over entire range. Outperforms most pumps in its class.
- Impeller passes 3/4 inch spherical solids.
- Enclosed impeller design eliminates possibility of jamming or corrosion between impeller and volute.

DURABLE MOTOR WILL DELIVER MANY YEARS OF RELIABLE SERVICE

- Oil-filled motor for maximum heat dissipation and constant bearing lubrication.
- High torque, permanent split capacitor (PSC), single phase motors. No starting switches or relays to wear out.
- Double tandem seal option for extra motor protection, tough effluent pumping applications.
- Optional seal leak probe warns of seal leak condition. (Dual seal motors only.) Helps prevent costly motor damage.
- On-winding current and temperature sensitive overload to protect against costly burnout due to overload.

THE P SERIES EFFLUENT PUMPS ARE DESIGNED FOR YEARS OF MAINTENANCE FREE OPERATION

- Volute seal ring is replaceable. Restores pump to original performance if wear should occur.
- Motor is held in place by four screws. Easily removed if service is ever needed.

PRODUCT CAPAILITIES

Capacities To	60 gpm	227 lpm
Heads To	124 ft.	37.8 m
Max. Spherical Solids	3/4 in.	19 mm
Liquids Handling	domestic effluent & drain water	
Intermittent Liquid Temp.	up to 140° F	up to 60° C
Motor Electrical Data	1/2 hp, 115 or 230 volts, 1 ph 1 hp, 230 volts, 1 ph oil-filled, permanent split capacitor type, 3450 rpm, 60 Hz	
Motor Insulation	Class B (130° C)	
Third Party Approvals	UL, CSA	
Acceptable pH Range	6 - 9	
Specific Gravity	.9 - 1.1	
Viscosity	28 - 35 SSU	
Discharge, NPT	1 1/2 in.	38.1 mm
Min. Sump Dia. Simplex	24 in.	61 cm
Duplex	36 in.	91.4 cm

Construction Materials	
Motor Housing, Volute	cast iron, Class 30, ASTM A48
Enclosed Single Vane Impeller	engineered thermoplastic
Impeller Wear Ring	304 SST
Volute Sealing Ring	Buna-N
Shaft	416 SST
Power Cord	20 ft. 16/3 SJOW/SJOW-A
Shaft Seals Standard	single carbon & ceramic
Opt. Lower	tungsten carbide
Fasteners	300 Series SST

WHERE INNOVATION MEETS TRADITION

Myers[®]

Pentair Water

POWER AND SEAL PROBE CORDS

Jacket sealed with compression fittings. Individual wires potted with epoxy to prevent wicking in case of cord damage.

MOTOR HOUSING

Cast iron for efficient heat transfer and corrosion resistance.

MOTOR

½ and 1 HP single phase, 60 Hz, 3450 rpm. Permanent split-capacitor (PSC) motors have built-in on winding overload protection, oil-cooled and lubricated.

BEARINGS

Upper and lower ball bearings support rotor. Take radial and thrust loads.

SHAFT

416 SST for strength and corrosion resistance.

SHAFT SEAL(S)

Single or optional double tandem seals with carbon and ceramic faces.

SEAL LEAK PROBES

Optional probes detect water leakage in seal housing. Activates warning light (double seal pumps only.)

ENCLOSED SINGLE VANE IMPELLER

high efficiency. Passes ¾" spherical solids with stainless steel wear ring.

HIGH EFFICIENCY CAST IRON VOLUTE

Corrosion resistant. Passes ¾" spherical solids. 1½" NPT discharge.

VOLUTE/IMPELLER SEAL RING

Maintains high efficiency and reduces recirculation. Replaceable.

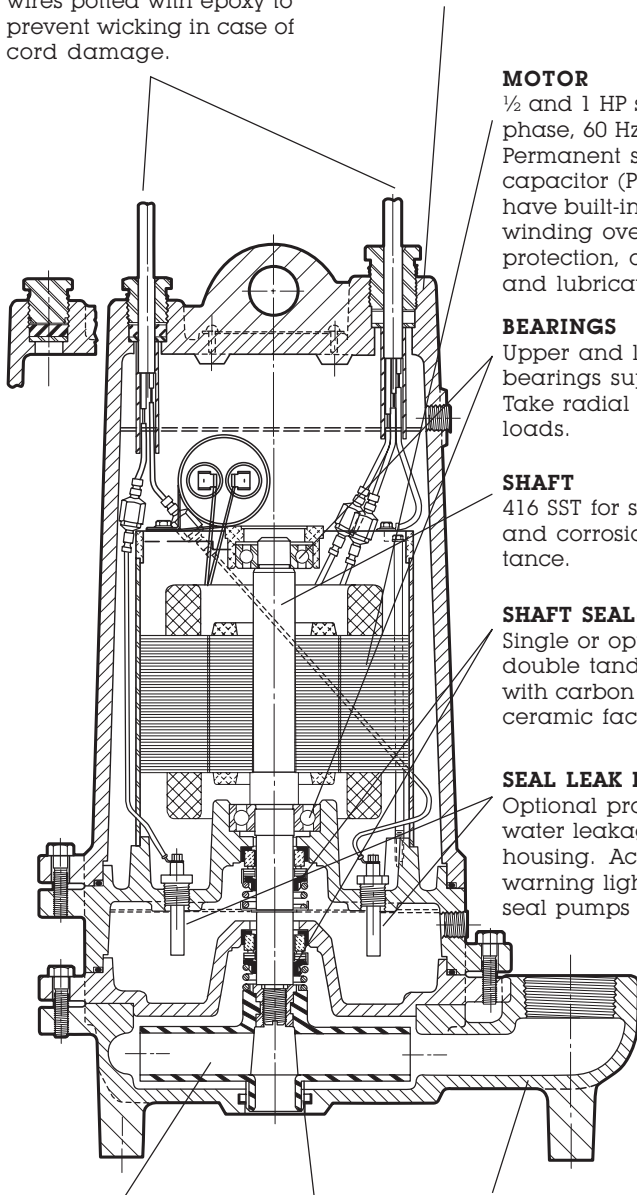

DIMENSIONS

(dimensions in mm)

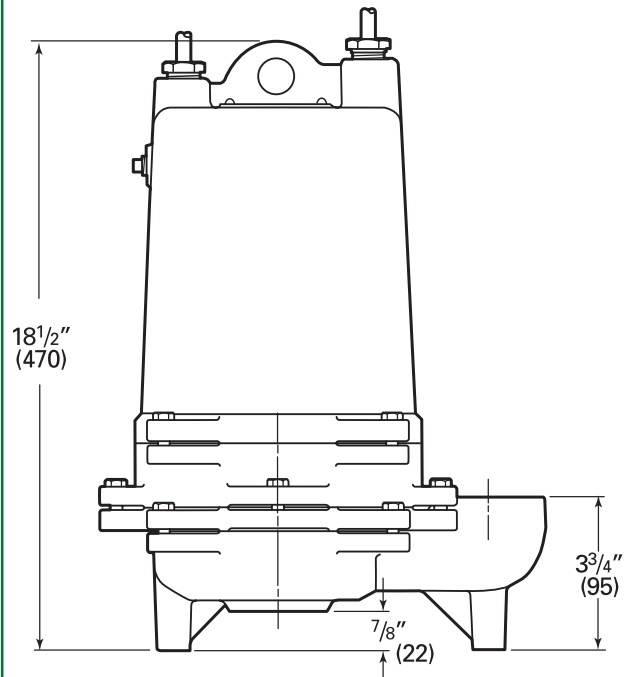
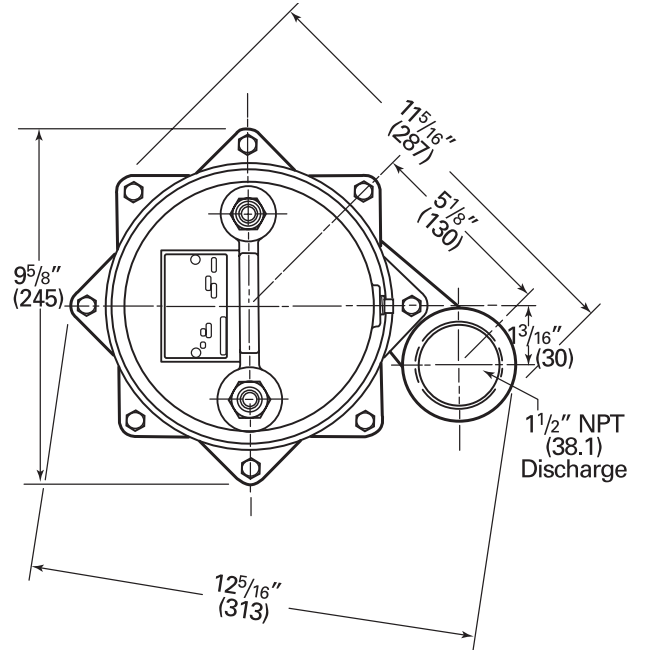

PUMP PERFORMANCE

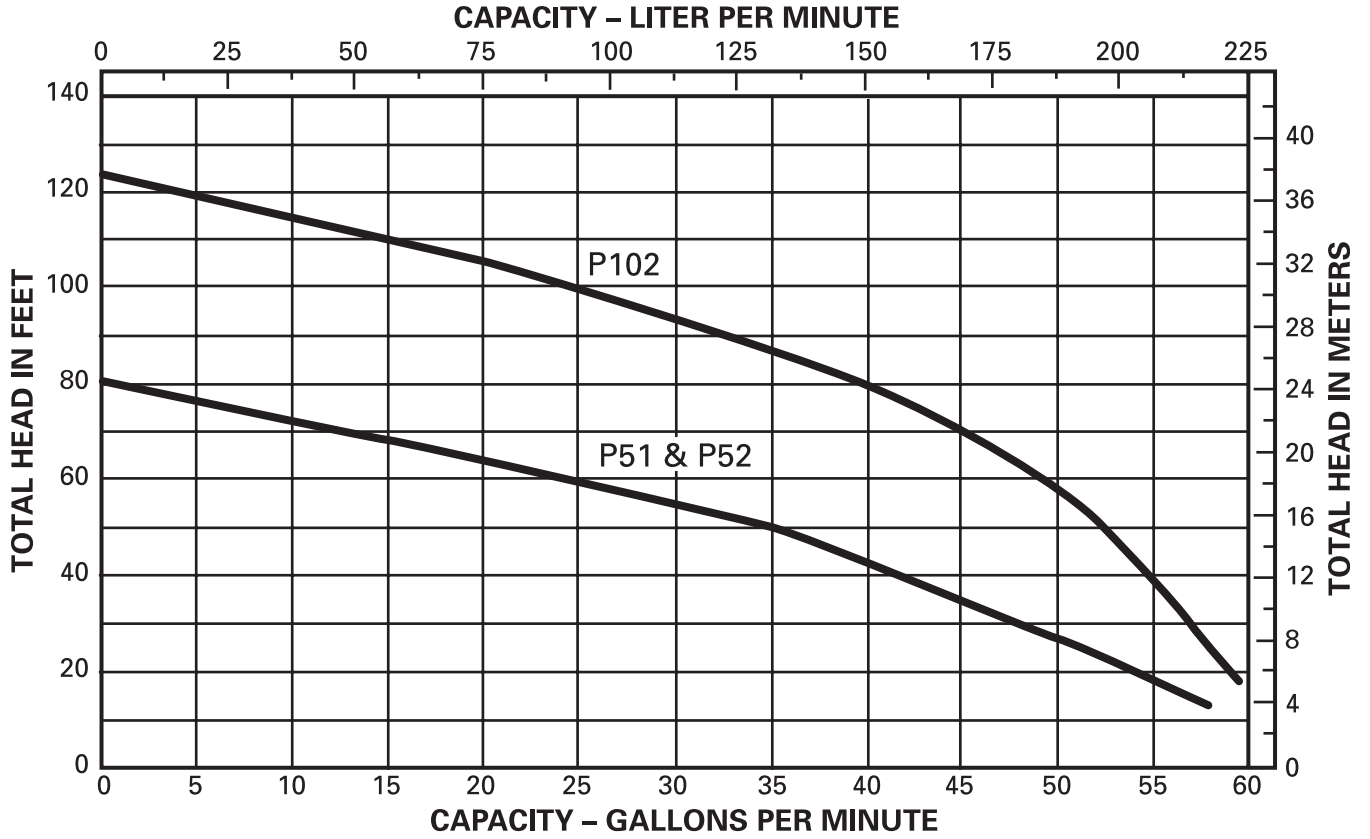

P50 and P100 SERIES

SPECIFICATIONS

EFFLUENT PUMPS - Pumps shall be F. E. Myers model P Series effluent pumps selected in accordance with the following design criteria:

Number of Pumps:	_____
Primary Design Flow:	_____
Primary Design Head:	_____
Minimum Shut-off Head:	80' (P51/P52) 124' (P102)
Motor Horsepower:	.5 (P51/P52) 1 (P102)
Motor Speed:	3450 RPM
Electrical:	P51 - 115V, 1 phase
	P52/P102 - 230V, 1 phase

PUMP - The pump shall be designed to handle septic tank effluent and be capable of passing 3/4 inch spherical solids. The pump shall be capable of handling liquids with temperatures to 140°F intermittent and shall be capable of running dry without damage to the seals or bearings.

MOTOR - The pump motor shall be of the submersible type. Single phase motors shall be of the permanent split capacitor type with no relays or starting switches. Stator winding shall be of the open type with Class B insulation rated for 130°C maximum operating temperature. The winding housing will be filled with clean dielectric oil to lubricate bearings, seals, and transfer heat from the windings to the outer shell. The motor assembly shall be of the standard frame design and shall be secured in place by four threaded fasteners allowing for easy field serviceability.

The motor shall be capable of operating over the full range of the performance curve without overloading the motor and causing any objectionable noise or vibration. The motor shall have two bearings to support the rotor; an upper ball bearing to accommodate radial loads and a lower ball bearing to take thrust and radial loads. Ball bearings shall be designed for a B-10 life of 50,000 hours. A heat sensor thermostat and overload shall be attached to the top end of the motor windings and shall be wired in series with the windings to stop the motor if the motor winding temperature reaches 266°F. The overload thermostat shall reset automatically when the motor cools to a safe operating temperature.

POWER CORD - The motor power cord shall be 14-3 SJOW/SJOWA or SOOW. The cable jacket shall be sealed at the motor entrance by means of a rubber compression washer and compression nut. A heat shrink tube filled with epoxy shall seal the outer cable jacket and the individual leads to prevent water from entering the motor housing.

SEAL CHAMBER - The motor shall be protected by two (2) rotary shaft seals mounted in tandem with an oil filled chamber separating the seals. The seals shall have carbon and ceramic seal faces diamond lapped to a tolerance of one light band. Metal parts and springs for seals shall be 300 series stainless steel. Two optional electrical sensing probes shall be mounted in the seal chamber to detect any water leakage past the lower seal. The sensing probes shall be connected to a red warning light in the control panel. The warning light shall serve to indicate a seal leak and shall not stop the pump.

PUMP IMPELLER - The pump impeller shall be of the single vane enclosed type. The impeller shall be constructed of an engineered thermoplastic. A stainless steel wear ring shall be molded into the neck of the thermoplastic impeller to provide a sealing surface. A replaceable Buna-N sealing cup shall effect a seal between the volute and impeller in order to maintain high efficiency and prevent recirculation. The impeller shall be threaded onto the 416 stainless steel pump/motor shaft.

PUMP AND MOTOR CASTINGS - All casting shall be of high tensile strength Class 30 gray cast iron. Castings shall be treated with phosphate and chromate rinse and painted with a high quality air dry alkyd enamel.

FASTENERS - All exposed fasteners shall be of 300 series stainless steel.